

Genius

Desktop CPU Cooler



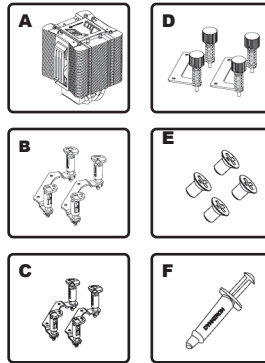

Parts

- (A) CPU Cooler
- (B) Intel LGA 1366 Mounting Kit
- (C) Intel LGA 775 Mounting Kit
- (D) AMD AM2/AM2+/AM3 Mounting kit
- (E) Screws
- (F) Thermal Compound

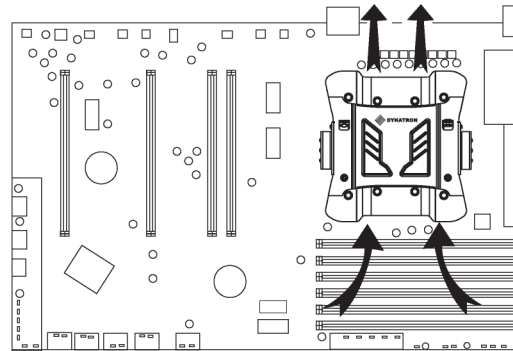

Airflow Direction



Contact

Dynatron Corp. Headquarters
41458 Christy Street, Fremont, CA 94538
+1 (510) 498-8888 Main Phone

Dynatron LA Office
337 Paseo Sonrisa, Walnut, CA 91789
+1 (909) 598-2222 Main Phone

Dynatron Taiwan office
8F, No. 35, Lane 221, Gang-Chian Rd,
Nai Hu, Taipei 114, Taiwan R.O.C.
+886 (02) 27995799 Main Phone

Website :
<http://www.dynatron-corp.com/>

Install Step

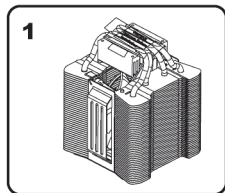

Remove the protective film on the bottom of the CPU Cooler (A)

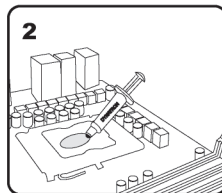

Apply thin layer of thermal compound (F) to the surface of the CPU processor

Intel LGA 775

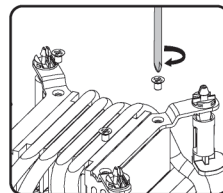

Assemble the Intel LGA 775 retention bracket mounting kit (C)(E)

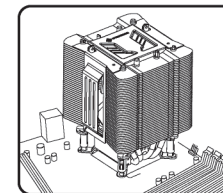

Secure the CPU cooler (A) to the motherboard

Intel LGA 1366

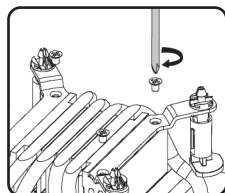

Assemble the Intel LGA 1366 retention bracket mounting kit (B)(E)

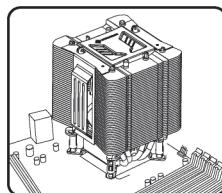

Secure the CPU cooler (A) to the motherboard

AMD AM2/AM2+/AM3

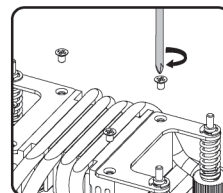

Assemble the AMD AM2/AM2+/AM3 retention bracket mounting kit (D)(E)

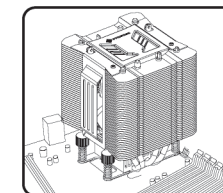

Secure the CPU cooler (A) to the motherboard

Connect Fan Cable

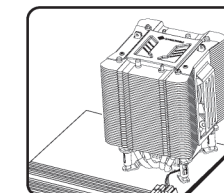

Connect the PWM function fan to the motherboard.