



# DYNATRON CORPORATION

TOP MOTOR TECHNOLOGY(HUIZHOU)CO,LTD

## Specification for Approval

Customer:		
Model Number:	DB127015BH -PWMG	
I Part Number:		
Issued Date:	Wednesday June 04 2009	
<b>Customer Approval</b>		
Approval:	Check:	
<p>Corporate Headquarters  <b>Dynatron Corporation</b>          42307 Osgood Road, #F,          Fremont, California 94539,          U.S.A.          Tel: 510-498-8888          Fax: 510-498-8488</p>	<p>Manufactory  <b>TOP MOTOR TECHNOLOGY(HUI          ZHOU)CO,LTD</b>          Baishi Village, Qiuchang Town,          Huiyang Dist, Huizhou City, Guangdong          Province, P.R. China          Tel: 86-752-353-5591 (Rep.)          Fax: 86-752-353-5592</p>	
<p>Los Angeles Office (U.S.A.)          337 Paseo Sonrisa,          Walnut, California 91789          U.S.A.          Tel: 909-598-2222          Fax: 909-598-8158</p>	<p>Taipei Office (Taiwan, R.O.C.)          8F, No. 35, Lane:221,          Gang Cian Road, Taipei,          Taiwan, R.O.C.          Tel: 886-2-2799-5799(Rep.)          Fax: 886-2-2799-9577</p>	
Approval:	Check:	Initiator



# DYNATRON CORPORATION

*TOP MOTOR TECHNOLOGY(HUIZHOU)CO,LTD*

	CONTENTS	Page
1.	SCOPE	3
2.	ELECTRICAL CHARACTERISTICS	3
3.	MECHANICAL CHARACTERISTICS	4
4.	ENVIRONMENTAL	4
5.	PROTECTION	5
6.	ATTACHMENTS	5
	a. Product Dimension	6
	b. Electrical specifications for pwm production	7-8



# DYNATRON CORPORATION

## TOP MOTOR TECHNOLOGY(HUIZHOU)CO,LTD

### 1. SCOPE

This specification defines the electrical and mechanical characteristics of the □ AC / ■ DC Brush less(□Sleeve Bearing / □ 1-Ball Bearing /■ 2-Balls Bearing) axial flow fan, which is carefully designed and manufactured for your special needs by Dynatron Corporation.

### 2. ELECTRICAL CHARACTERISTICS

Items		Description		
1.	Rated Voltage	DC 12 V		
2.	Operating Voltage	10.8V-13.2V		
3.	PWM Frequency	Duty Cycle =0-20%	Duty Cycle =50%	Duty Cycle =100%
4.	Start Voltage	H: 7V		
5.	Air Flow – At rated voltage zero static pressure (minimal value)	0.062 m <sup>3</sup> /z min (2.185CFM)	0.1857 m <sup>3</sup> / min (6.555CFM)	0.371 m <sup>3</sup> / min (13.11CFM)
6.	Static Pressure – At rated voltage At zero air flow	1.281mm-H <sub>2</sub> O (0.0504inch-H <sub>2</sub> O)	11.53mm-H <sub>2</sub> O (0.454inch-H <sub>2</sub> O)	46.121 mm-H <sub>2</sub> O (1.816inch-H <sub>2</sub> O)
7.	Input Current (Max.)	0.04A	0.12A	0.7A
8.	Speed (Max.)	1000RPM ±200	3000RPM ±10%	6000RPM ±10%
9.	Acoustical Noise	14.792dBA	38.649dBA	51.4dBA(Max )
10.	Input Power	0.48W	1.44W	8.4W
11.	Insulation Resistance – Between Frame and Terminal	10 M ohm at DC 500 V		
12.	Dielectric Strength – Between Frame and Terminal	5 mA (Max.) @ AC 500 V 60 Hz 1 min.		
13.	Life – Continuous operating under normal temperature (25 °C or 77 °F)	50,000 hours		
14.	Rotation	Clockwise Air Discharged		
15.	Autorestart Time	3-5sec		



# DYNATRON CORPORATION

## TOP MOTOR TECHNOLOGY(HUIZHOU)CO,LTD

16	Lead Wires	UL 1007, awg 28 or Equivalent “-”: Black; “+”: Yellow;”s”: Green. ”PWM”: Blue.
----	------------	---

### 3. MECHANICAL CHARACTERISTICS

Items		Description
1.	Dimension	Display as Drawing
2.	Frame	aluminium
3.	Impeller	PBT UL94V-0 (Black GP)
4.	Bearing System	Two Ball Bearing
5.	Weight	60±10grams

### 4. ENVIRONMENTAL

Items		Description
1.	Operating Temperature	- 10 °C ~ + 65 °C (65 %RH)
2.	Storage Temperature	- 30 °C ~ + 70 °C (65 %RH)
3.	Vibration Test	Displacement Amplitude: 0.75mm(Equivalent 10G) Frequency Range:10Hz<->55Hz/30SEC. Lineair Scanning 120 Cycle Endurance Timer Per Axis:30Min. Orientation:X,Y,Z.
4.	Drop Test	Motor withstands one free body drop from 30 cm in high onto 10 mm thickness of wooden board for each of the three faces in minimum packing condition.
5.	Acoustic Noise	14.792dBA 38.649dBA 537dBA– Curve (Max) Measuring Condition – Under rated voltage in semi-anechoic chamber equipment sound level meter. (Figure A.)



# DYNATRON CORPORATION

TOP MOTOR TECHNOLOGY(HUIZHOU)CO,LTD

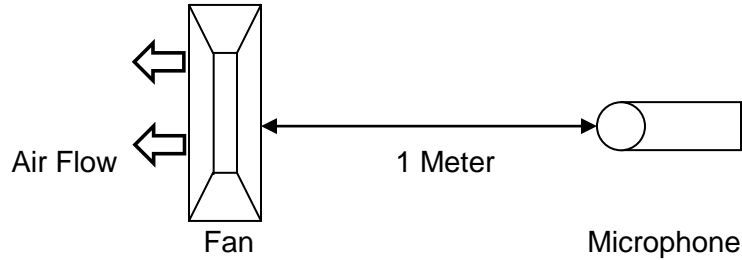

Figure A – Noise Level is measure at rated voltage in anechoic chamber in free air as above.

## 5. PROTECTION

Items		Description
1.	Polarity Protection	For polarity error connection to power, the circuit withstands reversed connection between positive and negative leads.
2.	Locked Rotor Protection	Motor winding protects the motor from damage i n 72 hours of locked rotor condition at rated volt age.

## 6.ATTACHMENTS

- a. Product Dimension
- b. Electrical specifications for pwm production



# DYNATRON CORPORATION

TOP MOTOR TECHNOLOGY(HUIZHOU)CO,LTD

## DIMENSIONS

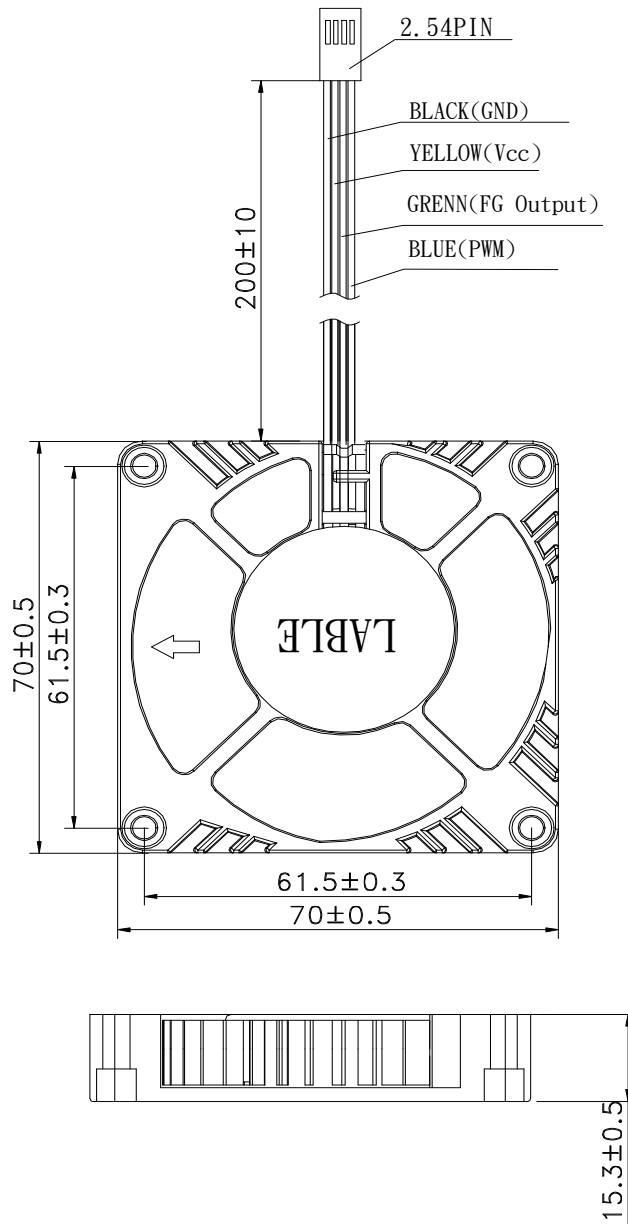

UNIT:MM

LEAD WIRE:1007 28AWG 105°C 300V UL, CSA APPROVAL



TOP MOTOR TECHNOLOGY  
(HUIZHOU)CO, LTD

DB127015XX

Tolerance	Vide Supra	Approval	
Unit	mm	Check	
Edition	1.0	Initiator	
Drawing Type	Dimensions	Remark	Date



# DYNATRON CORPORATION

## TOP MOTOR TECHNOLOGY(HUIZHOU)CO,LTD

### Electrical Specifications for PWM production

#### Voltage

Fan operating voltage shall be within the range 12 V +/- 1.2 V.

#### Current

Peak fan current draw during start-up operation (with 13.2 V applied, with fan operating in the free stream condition) shall not exceed 2.0 A.

Fan current spike during start-up operation (with 13.2 V applied, with fan operating in the free stream condition) shall be allowed to exceed 1.0 A for a duration of no greater than 1.0 sec.

#### Tachometer Output Signal

Fan shall provide tachometer output signal with the following characteristics:

- \*Two pulses per revolution
- \*Open-collector or open-drain type output
- \*Motherboard will have a pull up to 12V, maximum 13.2V

#### PWM Control Input Signal

The following requirements are measured at the PWM (control) pin of the fan cable connector: PWM Frequency: Target frequency 25kHz, acceptable operational range 21 kHz to 28 kHz  
Maximum voltage for logic low: VIL = 0.8V  
Absolute maximum current sourced: I<sub>max</sub> = 5mA (short circuit current)  
Absolute maximum voltage level: V<sub>Max</sub> = 5.25V (open circuit voltage)

#### Fan Speed Control

##### 1.1 Maximum Fan Speed Requirements

The maximum fan speed shall be specified for the fan model by the vendor and correspond to 100% duty cycle PWM signal input.

##### 1.2 Minimum Fan Speed Requirements

The vendor shall specify the minimum RPM and the corresponding PWM duty cycle. This specified minimum RPM shall be 30% of maximum RPM or less. The fan shall be able to start and run at this RPM. To allow a lower specified minimum RPM, it is acceptable to provide a higher PWM duty cycle to the fan motor for a short period of time for startup conditions. This pulse should not exceed 30% maximum RPM and should last no longer than 2 seconds.

#### R&D Support Information



# DYNATRON CORPORATION

## TOP MOTOR TECHNOLOGY(HUIZHOU)CO,LTD

### 1.3 Fan Speed Response to PWM Control Input Signal

The PWM input shall be delivered to the fan through the control signal on Pin 4. Fan speed response to this signal shall be a continuous and monotonic function of the duty cycle of the signal, from 100% to the minimum specified RPM. The fan RPM (as a percentage of maximum RPM) should match the PWM duty cycle within  $\pm 10\%$ . If no control signal is present the fan shall operate at maximum RPM.

Figure 1 Fan Speed Response to PWM Control Input Signal

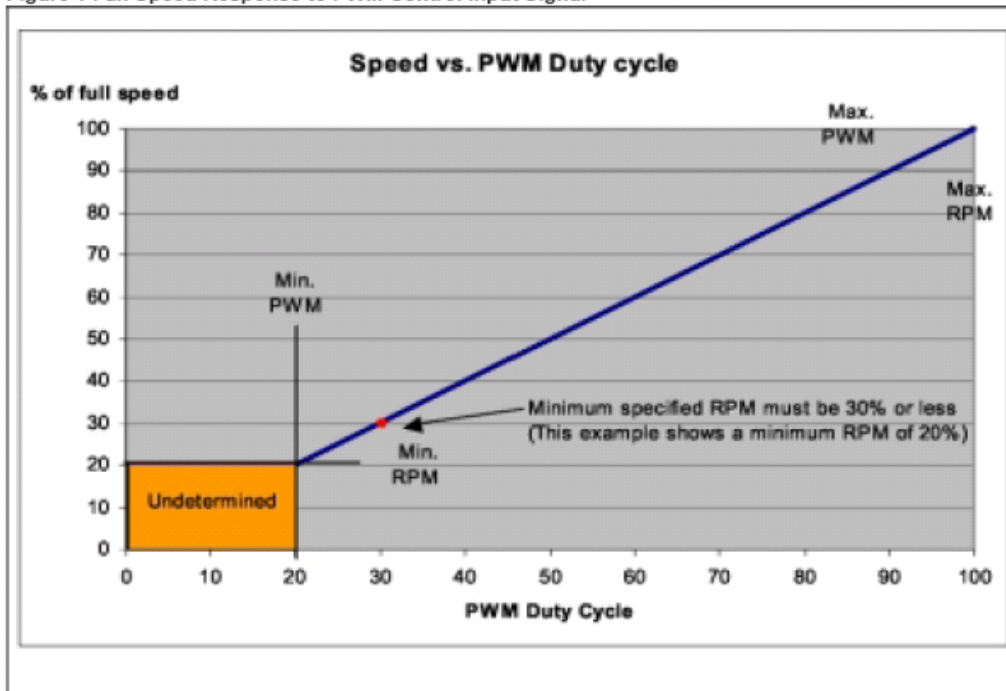

### 1.4 Operation Below Minimum RPM

For all duty cycles less than the minimum duty cycle, the RPM shall not be greater than the minimum RPM. The following graphs and definitions show three recommended solutions to handle PWM duty cycles that are less than the minimum operational RPM, as a percentage of maximum.

**Reference resource by Intel's 4-wire PWM Fan controlled specification.**

R&D Support Information